

*The OWC option*

- ❑ **Kymaner was created in 2005** to develop Wave Energy in Portugal and remains to this date the only Portuguese company exclusively devoted to this specialty.
- ❑ The strength of its team translates into the remarkable experience of its founding partners and collaborators in domains such as the **Oscillating Water Column and Hydropower**, gathered on the largest installations of this kind developed by Portuguese engineering in the world.

Services rendered by Kymaner correspond to its areas of qualified competence, supplying components and turnkey solutions for wave energy conversion, from Concept Development to O&M, involving:

- **Project Management**
  - Project Leading and Coordination
  - Licensing
- **Mechanical Design**
  - Concept and Detail Design
  - Structural Analysis
  - Manufacturing and Assembly Supervision
- **Supply Chain Development**
  - Steel Construction
  - Composite Materials
  - Electrical Engineering
- **Commissioning and Testing**
- **Operation and Maintenance**

Facing the future with confidence, Kymaner builds its vision on the following pillars:

- Consolidating carefully chosen **Partnerships**, looking for the complementarity required to deliver solutions of excellence
- **Flexibility of Solutions**, ranging from micro turbines to 1 MW solutions fit for installation in offshore floating OWC platforms
- **Sense of Timing**, taking advantage of this window for an emerging business opportunity
- **Internationalization**, focusing mainly in Europe



Kymaner recognizes that there is no single solution for all needs of wave energy exploration and that the market demands flexibility and expects integration of past experiences to build on lessons learned. The response of Kymaner to this demand is based on a variety of solutions adapted to the most frequent requirements in Wave Energy exploration:

- ❑ Compact turbo-generator (20-200kW) for breakwaters
- ❑ Middle size OWC solutions (200-600kW) for nearshore and offshore power stations
- ❑ Floating OWC applications (>750kW);
- ❑ **Modular systems** for command and control with a wide range of applications

Project for prototype development:

- Develop a modular Wave Energy system
- Duration: 30 months

comprised of:

1. Modular high efficiency turbo-generator group
2. Command and Control module
3. Redundant Communication module

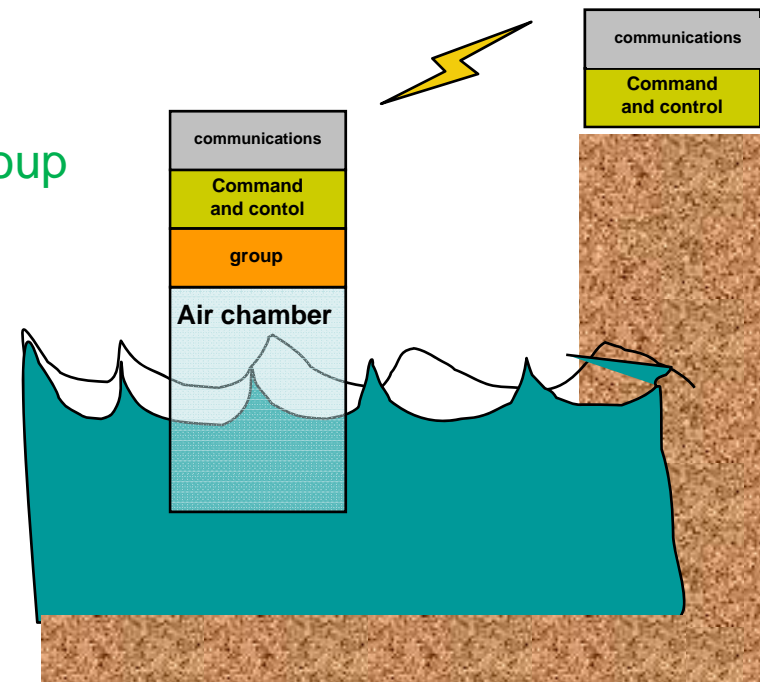

Logical components developed in the project

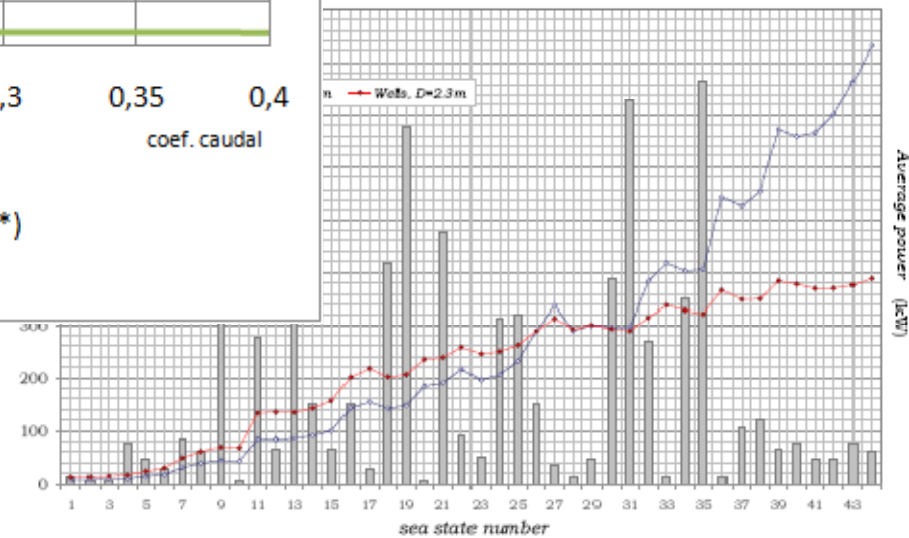
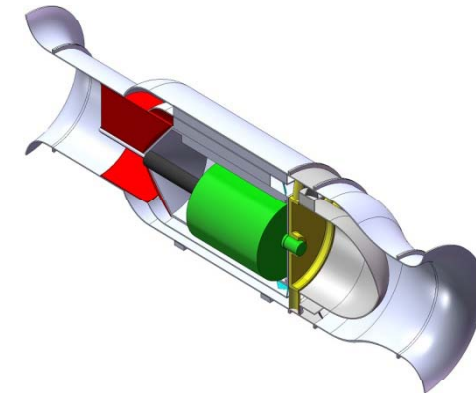
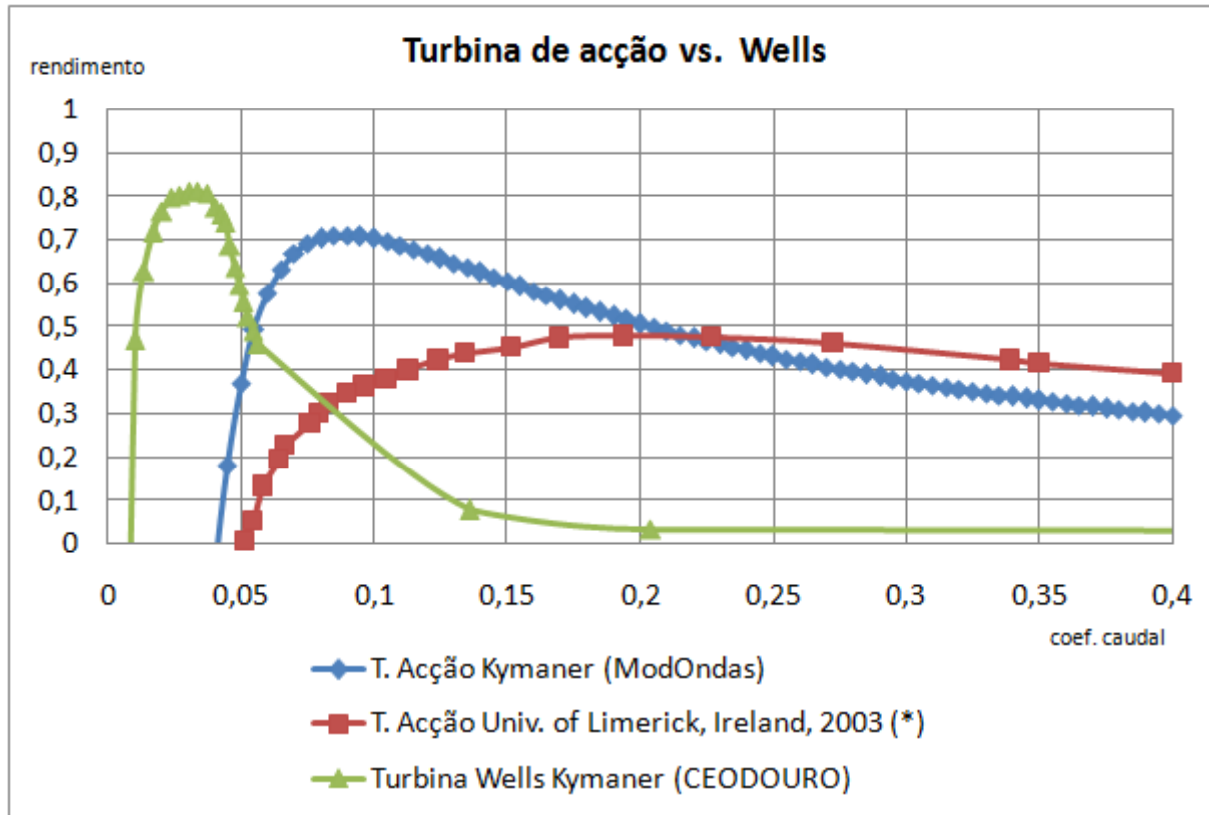

- in "Wells and impulse turbines in an OWC wave power plant: a preliminary comparison" - Mattia Scutto, 2004

- **Compact Group**- 60% rotor size of a traditional Wells solution with the same rated power;
- Installation of any module within **1 hour**
- **Portability** – modules applicable in most WEC;
- Resource to **composite materials** and proven maritime agents resistance solutions;
- **Low maintenance costs** ( this component representing up to 40% of the LCC)
- **WEB** enabled control



***OWC Experience***

**Client :** Wave Energy Center

**Location:** Pico Island - Azores

**Technology:** OWC - Wells turbine

**Type of Intervention:** **Rehabilitation**

**Timeframe:** 2008 -2009

**Description of Work:**

- Inspection and diagnosis of structure and equipment
- Wells turbine/generator rehabilitation
- Anti-corrosion protection
- Test data open access via Web
- Set up infrastructure for Open test site
- Civil structure damage repair

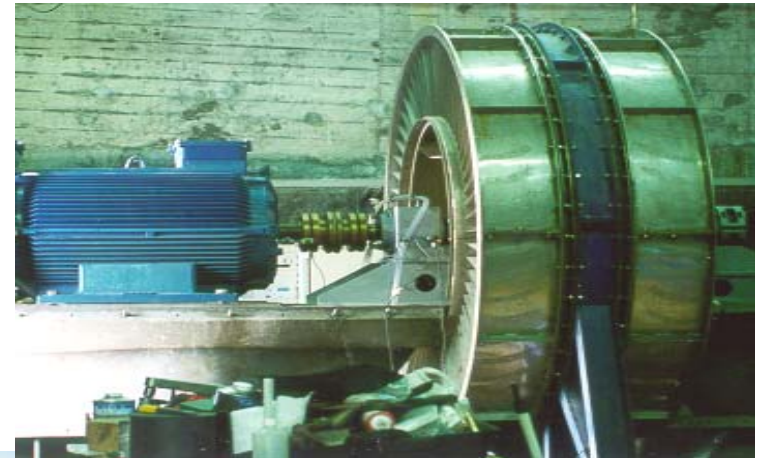

**Client :** IPTM/EDP

**Location:** Breakwater Foz do Douro - Porto

**Technology:** OWC - Wells 750kW

**Type of Intervention:** Supply and Commissioning

**Timeframe:** 2007 -2010 (suspended)

**Description of Work:**

- Detail Design
- Fabrication and Assembly
- Installation
- Commissioning and Test

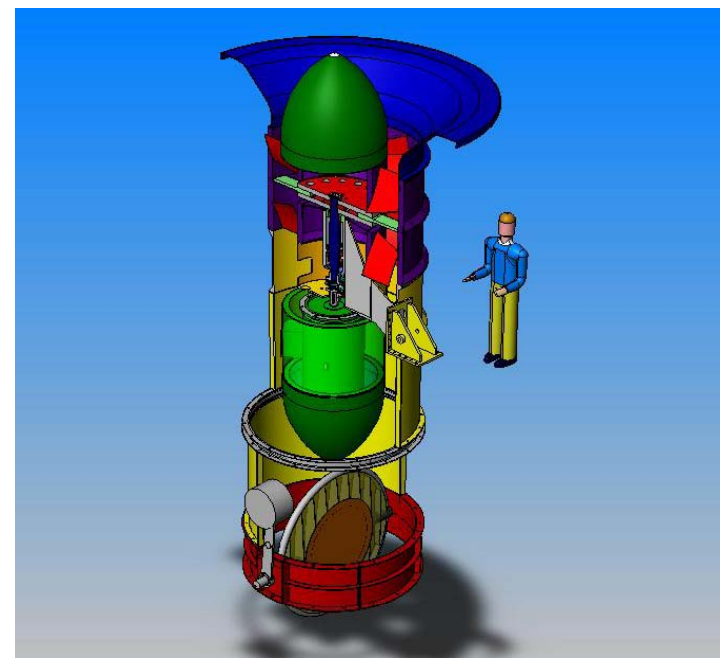

**Client:** CORES FP7 project

**Location:** Galway Bay - Ireland

**Technology:** Impulse Turbine

**Type of Intervention:** Supply and Commissioning

**Timeframe:** 2008 -2011

**Description of Work:**

- Detail Design
- Fabrication and Assembly
- Installation
- Commissioning and Test

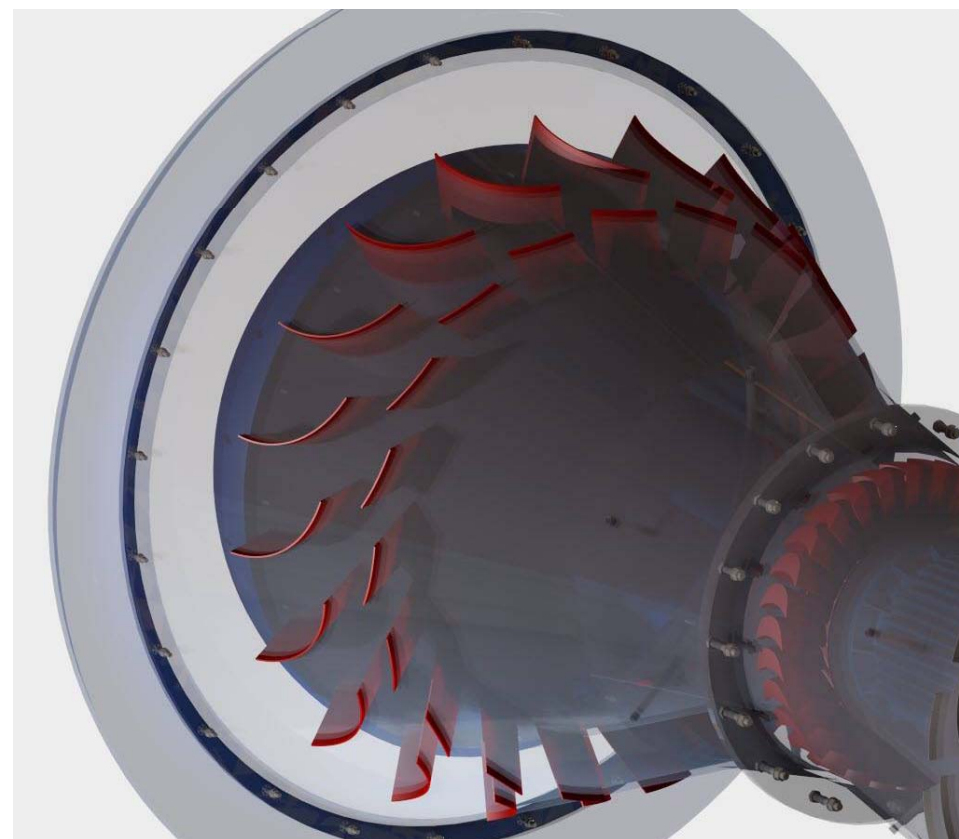

**Client : I+D**

**Location: IST Laboratory**

**Technology : Ultra-compact air turbine**

**Type of Intervention : Concept Development**

**Timeframe: 2010**

**Description of Work :**

- Detail Design
- Fabrication and Assembly
- Installation
- Commissioning and Test



*Thank You*